

ROCHESTER, NEW HAMPSHIRE

DEPARTMENT OF BUILDING SAFETY
 DIVISION OF BUILDING INSPECTION
 TELEPHONE: 603-332-3508
 FAX: 603-509-1912

Detached Garage Handout

Based On 2009 ICC IRC
 Page 1 of 3
 For Residential Use Only



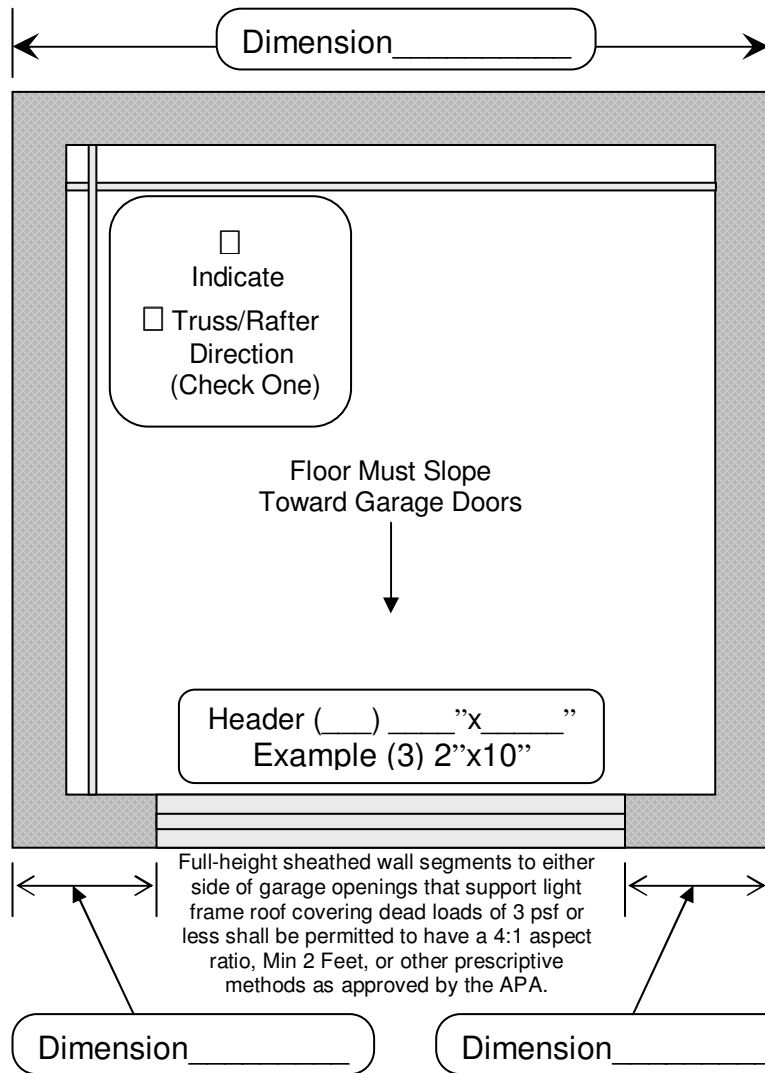

Foundations:

Single Story, 24' x 24', or Smaller
 May Go On A Floating Monolithic Slab.

A Story And One-Half And/Or Larger Than
 24' x 24' Must Have A Minimum Of A 4 Foot
 Frost Wall.

Single Story Minimum of
 2"x4" @ 16" On Center

One and A Half Story Minimum of
 2"x6" @ 24" On Center



ROCHESTER, NEW HAMPSHIRE

DEPARTMENT OF BUILDING SAFETY
 DIVISION OF BUILDING INSPECTION

TELEPHONE: 603-332-3508

FAX: 603-509-1912

Detached Garage Handout

Based On 2009 ICC IRC

Page 2 of 3

For Residential Use Only

Minimum Setbacks:

	Front Yard	Side Yard	Rear Yard	Distance From Other Buildings/Structures
Agricultural	35'	25'	50'	10'
Residential 1	25'	10'	25'	10'
Residential 2	15'	8'	25'	10'
Mobile Home Park	20'	15'	15'	10'

The Side And Rear Yards For Garages (Residential Use Only) In The Agricultural, Residence 1, And Residence 2 Districts Can Be Reduced By Special Exception, As Provided For In Section 42.23(c)(28)

A site plan must accompany the application for the Deck.

Steps To Obtain Building Permit

- Complete Page One And Two Of This Guide
- Fill Out Building Permit Application
- Provide Plot Plan On Back Of Building Permit Application
- Submit All Forms To The Department of Building Safety With Payment

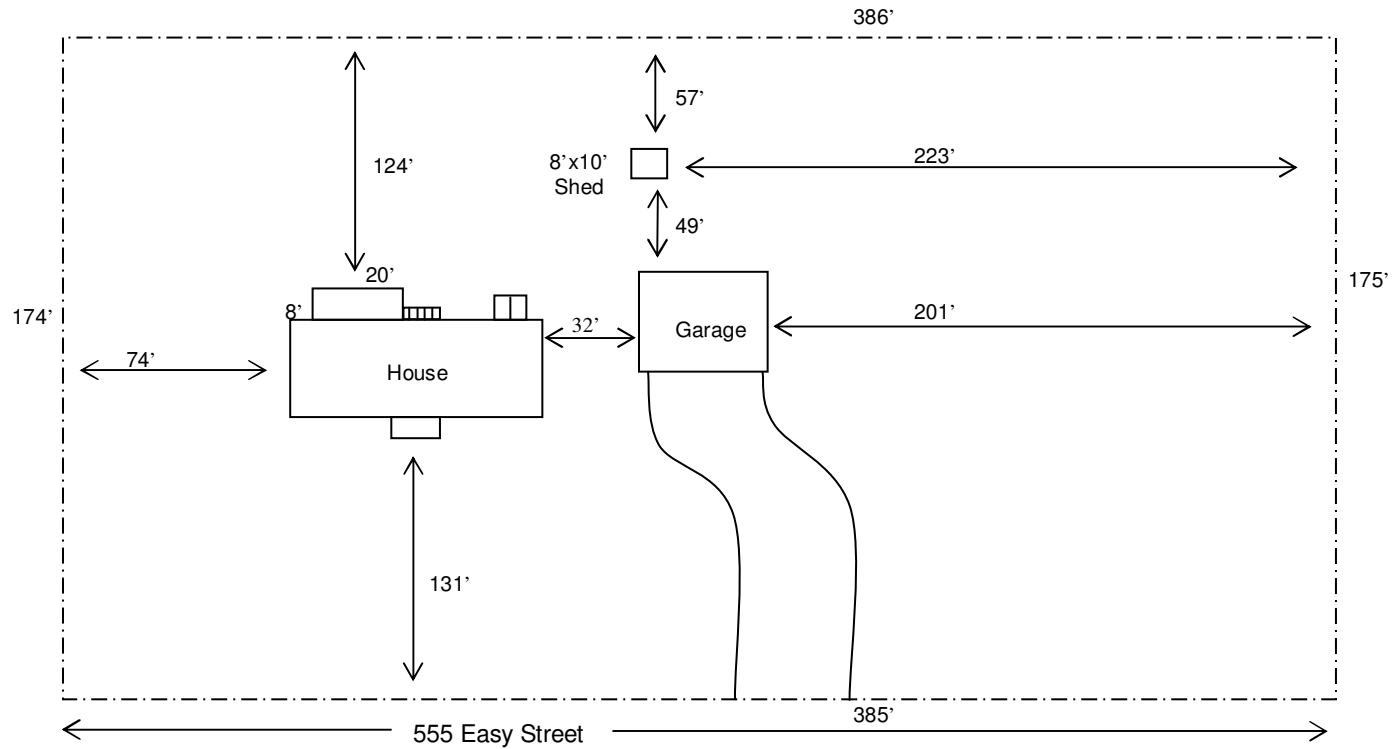

Sample Site Plan



ROCHESTER, NEW HAMPSHIRE
 DEPARTMENT OF BUILDING SAFETY
 DIVISION OF BUILDING INSPECTION
 TELEPHONE: 603-332-3508
 FAX: 603-509-1912

Detached Garage Handout

Based On 2009 ICC IRC
 Page 3 of 3
 For Residential Use Only