



ROCHESTER, NEW HAMPSHIRE

DEPARTMENT OF BUILDING SAFETY
DIVISION OF BUILDING INSPECTION

CITY HALL

TELEPHONE: 603-332-3508

FAX: 603-509-1912

Sheds

In Any Zoning District: (*except mobile home parks*) the minimum side and rear yard setbacks for a single-story outdoor storage sheds **144 square feet or less** floor area and not located on a permanent foundation and used in connection with a residential dwelling of four (4) or less dwelling units shall be **10 feet for each setback**.

- The minimum distance from other buildings and/or structures must be 10 feet.
- In all cases, the front setback requirements must be adhered to.

Mobile Home Parks: Only one single-storage building may be installed on any one mobile home lot. The maximum size shall not exceed 12' x 14' x 10' wall height. The minimum side and rear setbacks for mobile home parks are 15 feet. The minimum front yard setback is 20 feet.

- The minimum distance from other buildings and/or structures must be 10 feet.

Setbacks:

	Front	Side	Rear	Other Buildings/Structures
Agricultural	35'	25'	50'	10'
Residential 1	25'	10'	25'	10'
Residential 2	15'	8'	25'	10'
Mobile Home Park	20'	15'	15'	10'

A site plan must accompany the application for the storage shed.

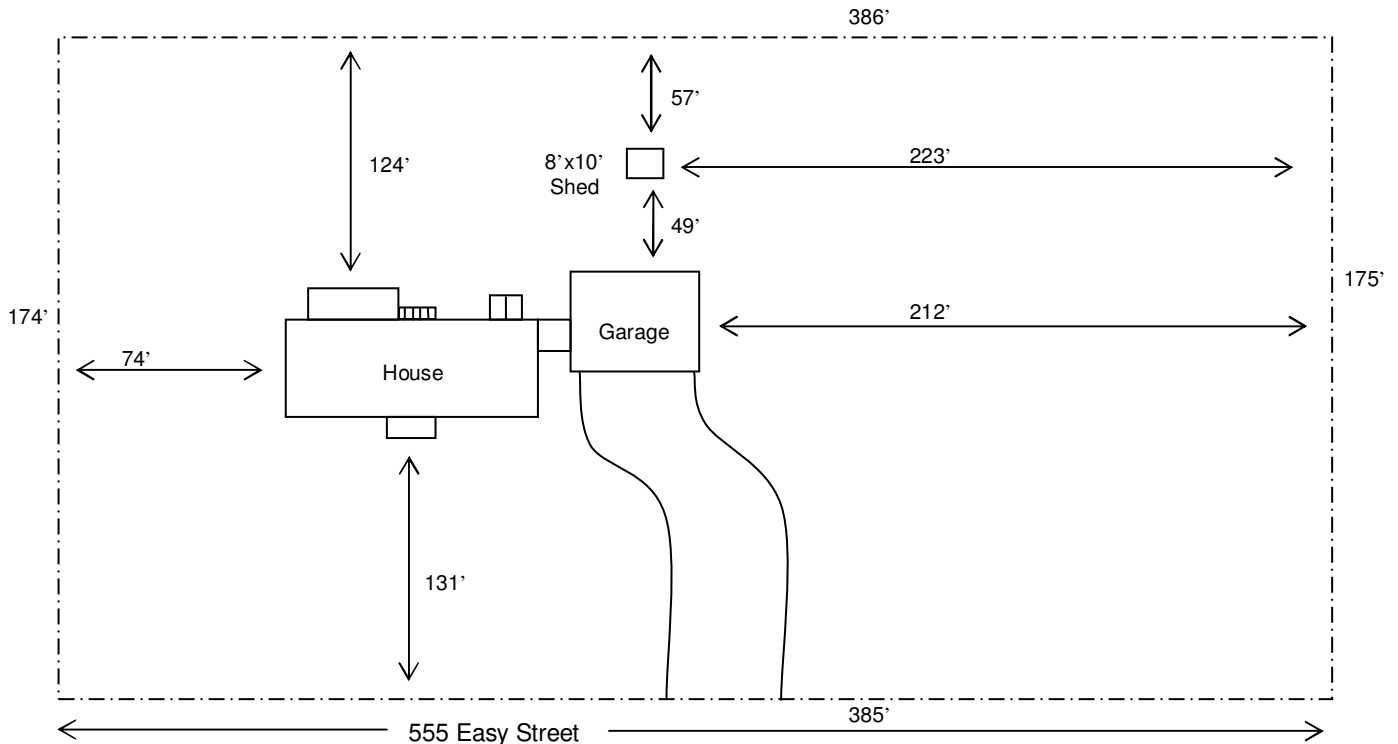

Sample Site Plan